

# SUNKIST *Sectionizer*

For safely preparing fresh-cut wedges, slices and halves.

**Q**uick & easy cleanup – dishwasher safe parts

**U**niform pieces for appealing presentation

**A**mazingly easy to use

**L**isted by NSF International

**I**nterchangeable blade cups – 7 different ones

**T**ime saving device pays for itself

**Y**ears of dependable service can be expected



*Available from your foodservice equipment dealer*

Contact us for the one nearest you:

(800) 383-7141 or (909) 933-2236 • Fax (909) 933-2169

Foodservice Equipment Sales, Sunkist Growers

720 East Sunkist Street, Ontario, CA 91761

[www.sunkistfs.com/equipment](http://www.sunkistfs.com/equipment)



**Part Number Description**

- S-1. Foot Pad (set of 6)
- S-2. Base Assembly
- S-3. Blade Cup w/cover (6 wedge)
- S-4. Blade Cup w/cover (6 slice) (fits part S-10 only)
- S-5. Blade Cup w/cover (4 wedge)
- S-6. Wedger Cup cover (sold w/ S-3, S-5, S-29, S-30, S-32, S-35)
- S-7. Slicer Cup cover (sold w/ S-4)
- S-8. Outer Shell
- S-8D. Pin & Thread Assembly
- S-9. Plunger Wedger (fits parts S-3, S-5, S-29, S-30, S-35)
- S-10. Plunger Slicer fits part S-4 only
- S-11. Crossbar Assembly
- S-12. Back Screw #8 x 1/2" (set of 8)
- S-13. Back Cover
- S-14. Spring Pin (set of 2)
- S-23. Gears & Shaft Set
- S-24. Base Side Screw 6-32 x 1 1/2" (Set of 10)
- S-25. Plastic Shaft Cover
- S-26. Handle
- S-27. Knob
- S-28. Bottom Screw #8 x 1 1/2" (set of 4)
- S-29. Blade Cup w/cover (8 wedge)
- S-30. Blade Cup w/cover (3-in-1)
- S-31. Plastic Production Stand (see below)
- S-32. Apple Corer Cup (fits S-33 only)
- S-33. Apple Plunger (fits S-32 only)
- S-34. Apple Corer Set
- S-35. Blade Cup w/cover (single)

# Sunkist

## Sectionizer

### Parts Information

Effective date April 1, 2003

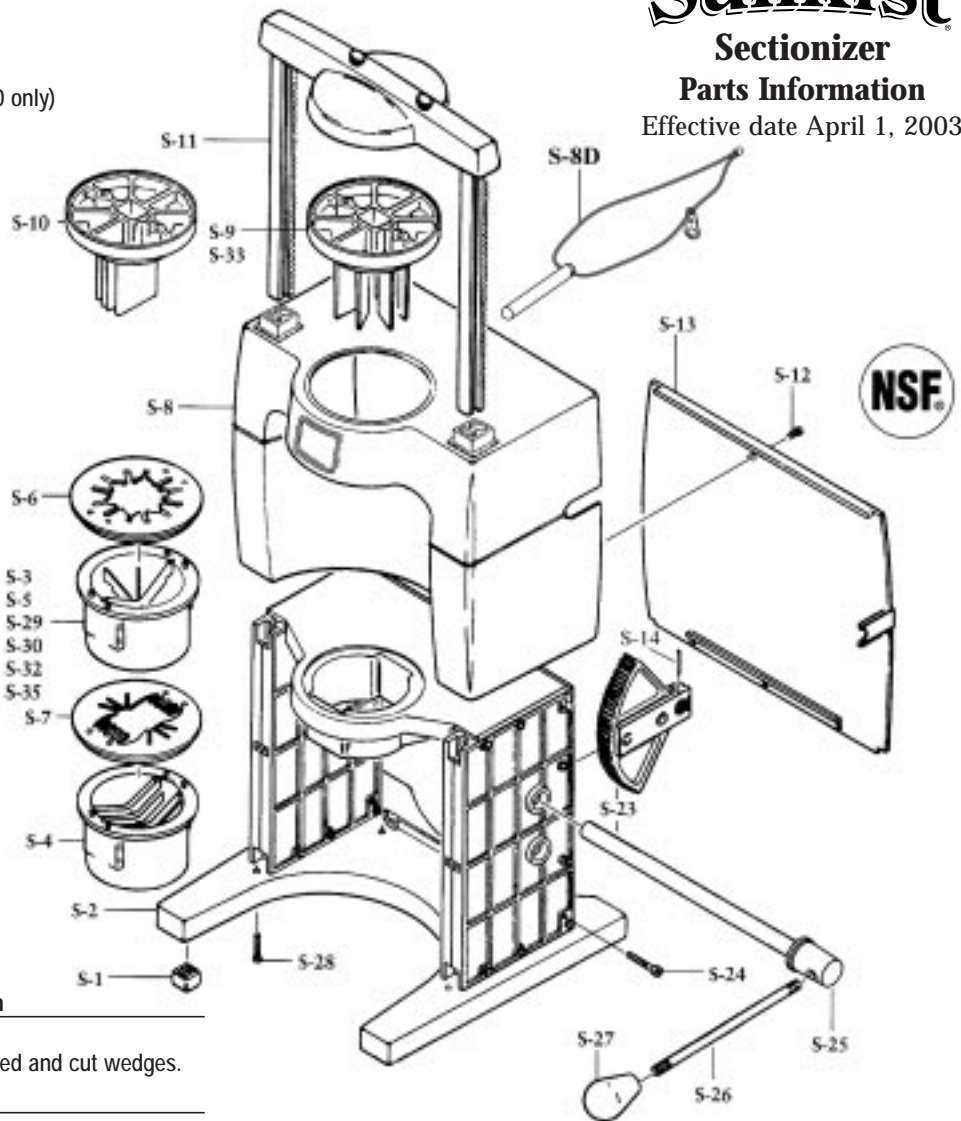

Complete Sectionizer Model #	Blade Cup Style	Description
S-101		4 Wedge 4 evenly spaced and cut wedges.
S-102		6 Wedge 6 evenly spaced and cut wedges.
S-103		6 Slice 6 slices 5/16" thick. Must use plunger #10.
S-104		8 Wedge 8 evenly spaced and cut wedges.
S-105		3-in-1 2 halves scored in 3 wedges each (for school foodservice).
S-106		Apple Model 6 evenly spaced and cut wedges with center core removed. Must use plunger # 33.
S-107		Single Cuts fruit in half.

**Specifications**

Safe...Listed by NSF International® .  
 Overall Dimensions . . . . .15 1/2" high, 15 1/4" wide, 13 1/8" deep  
 Net Weight . . . . .13 pounds  
 Shipping Weight . . . . .15 pounds  
 Cube . . . . .2.32  
 Carton Size . . . . .17 1/2" L x 13 1/2" W x 17 1/2" H

**Plastic Production Stand (Optional)**  
 Part Number S-31



A sturdy plastic stand that allows serving pans (not included) to pass under the sectionizer for greater production flexibility.  
 Overall Dimensions . . . . .5 3/4" high, 14 1/2" wide  
 Shipping Weight . . . . .2 pounds, 3 oz.